

WIRING DIAGRAM

MPB SEMI

230-400V 50-60Hz

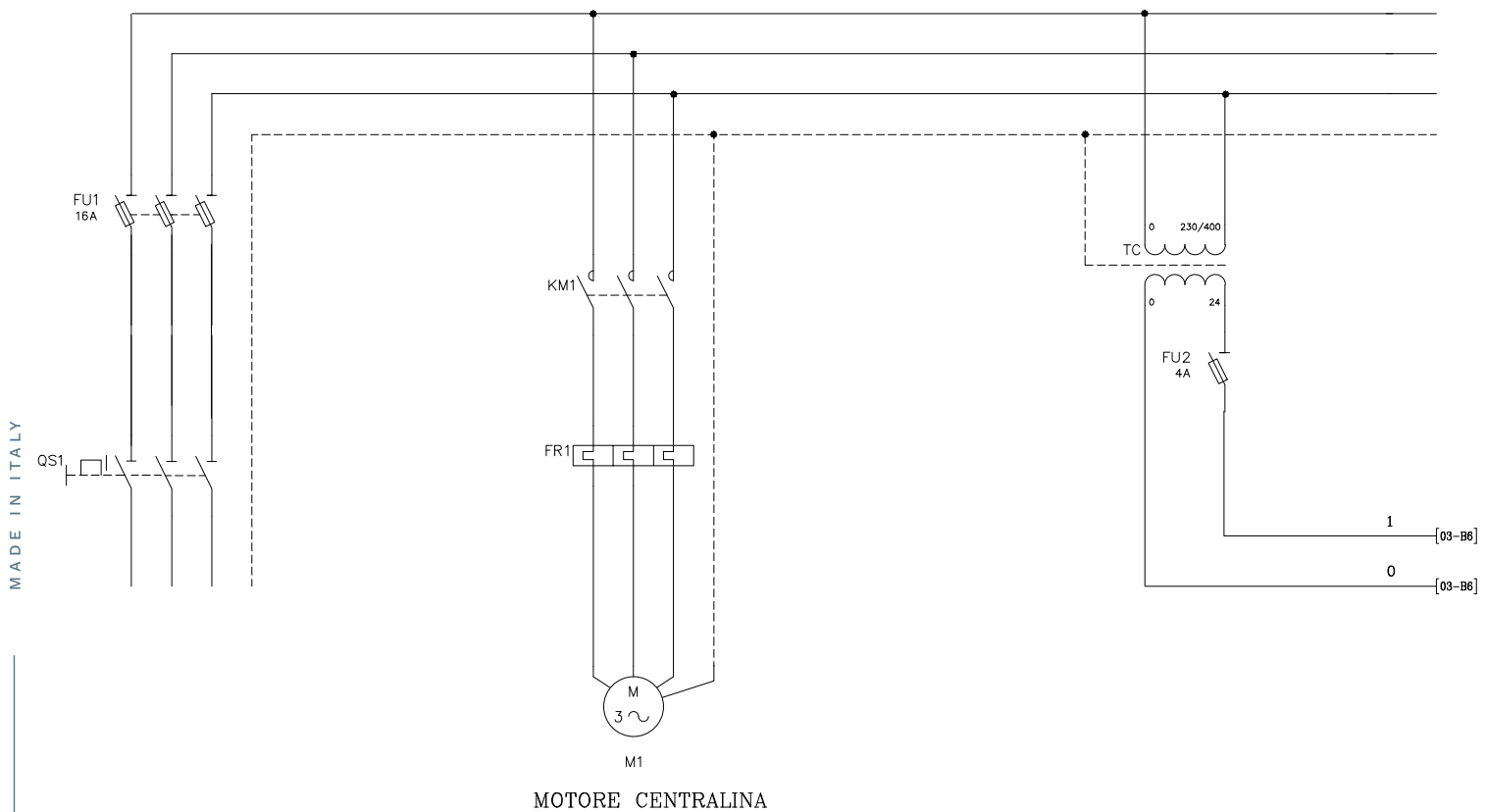

WIRING DIAGRAM

MPB SEMI

230-400V 50-60Hz

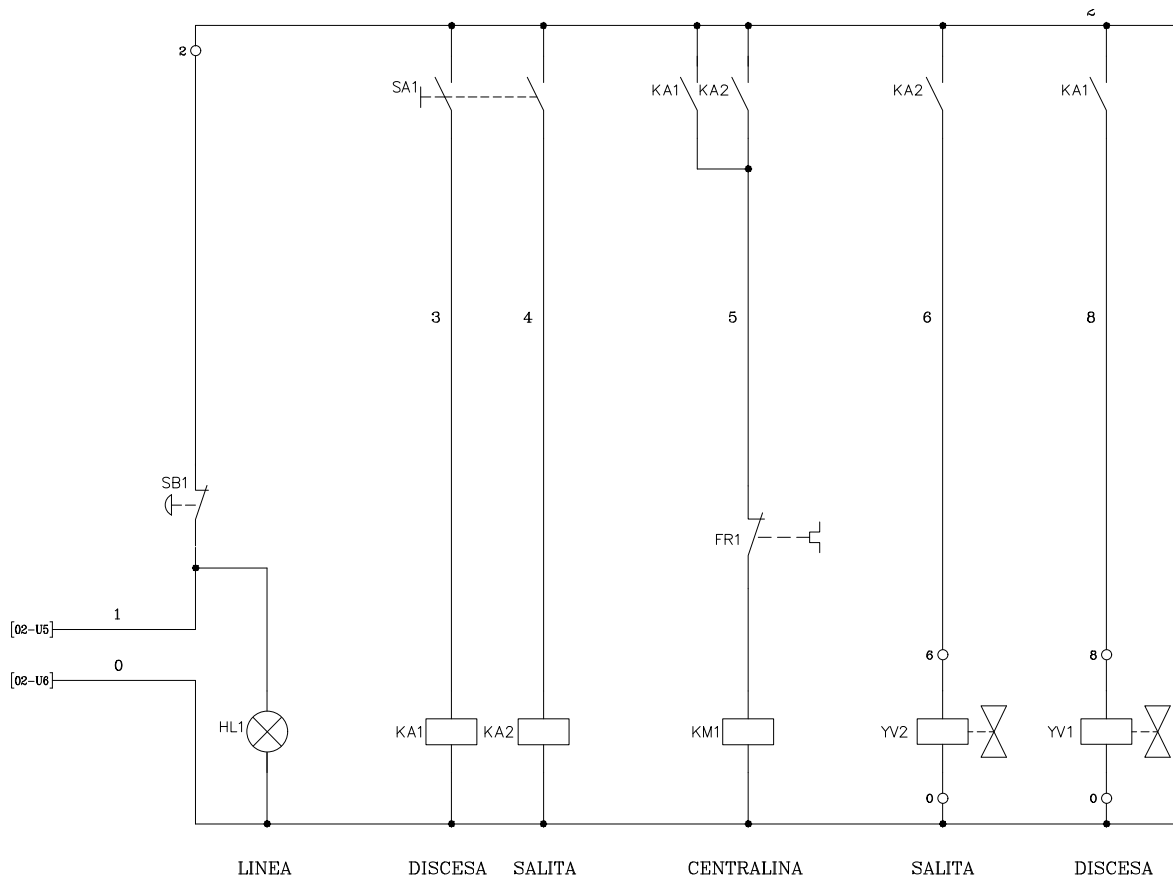

MADE IN ITALY

WIRING DIAGRAM

MPB SEMI

230-400V 50-60Hz

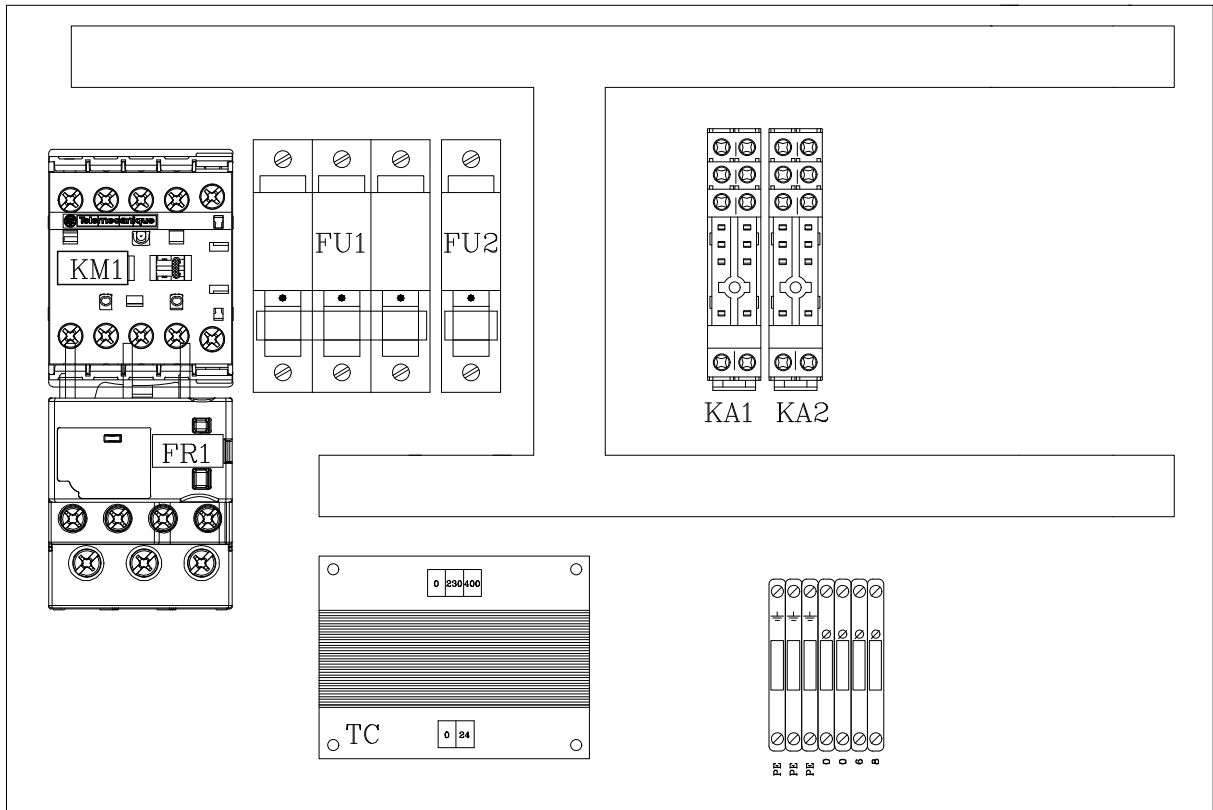

WIRING DIAGRAM

MPB SEMI

2P 230-400V 50-60Hz

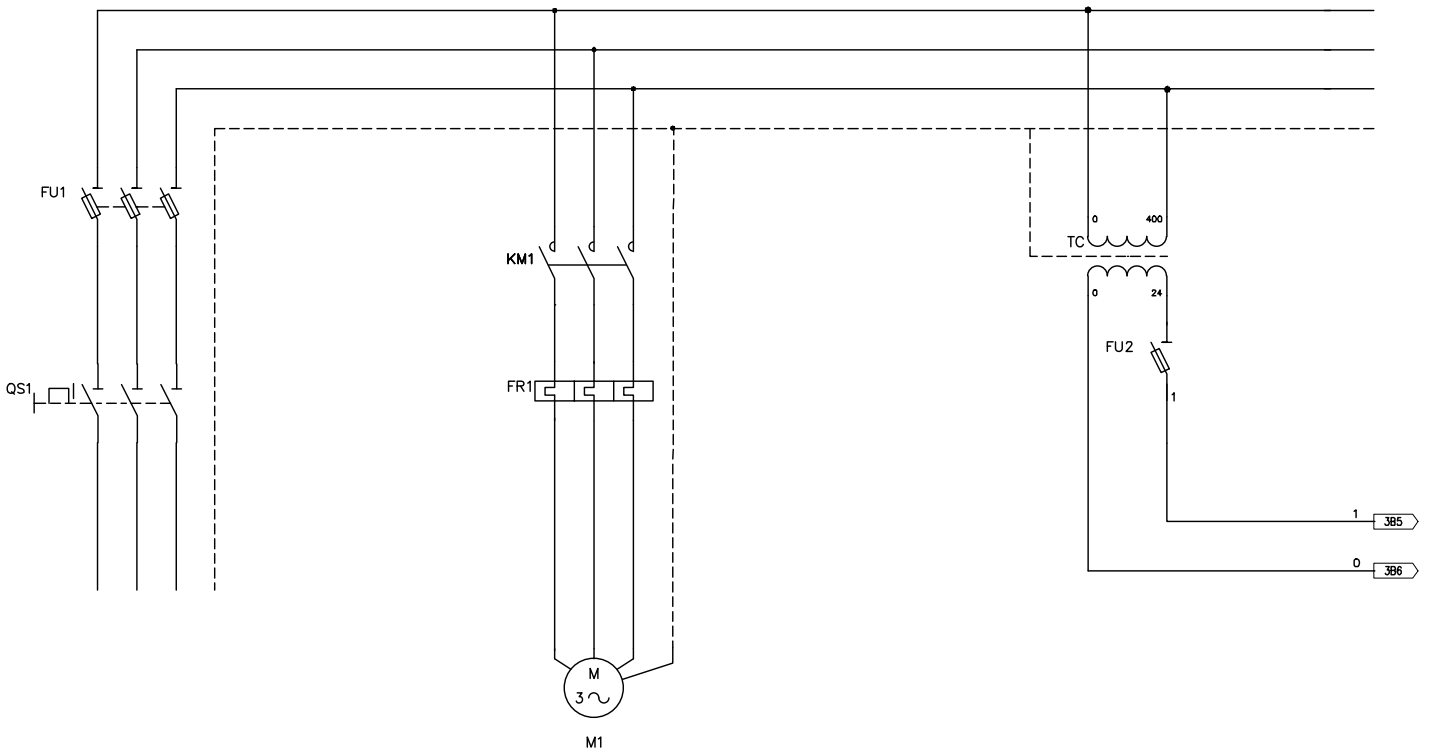

WIRING DIAGRAM

MPB SEMI

2P 230-400V 50-60Hz

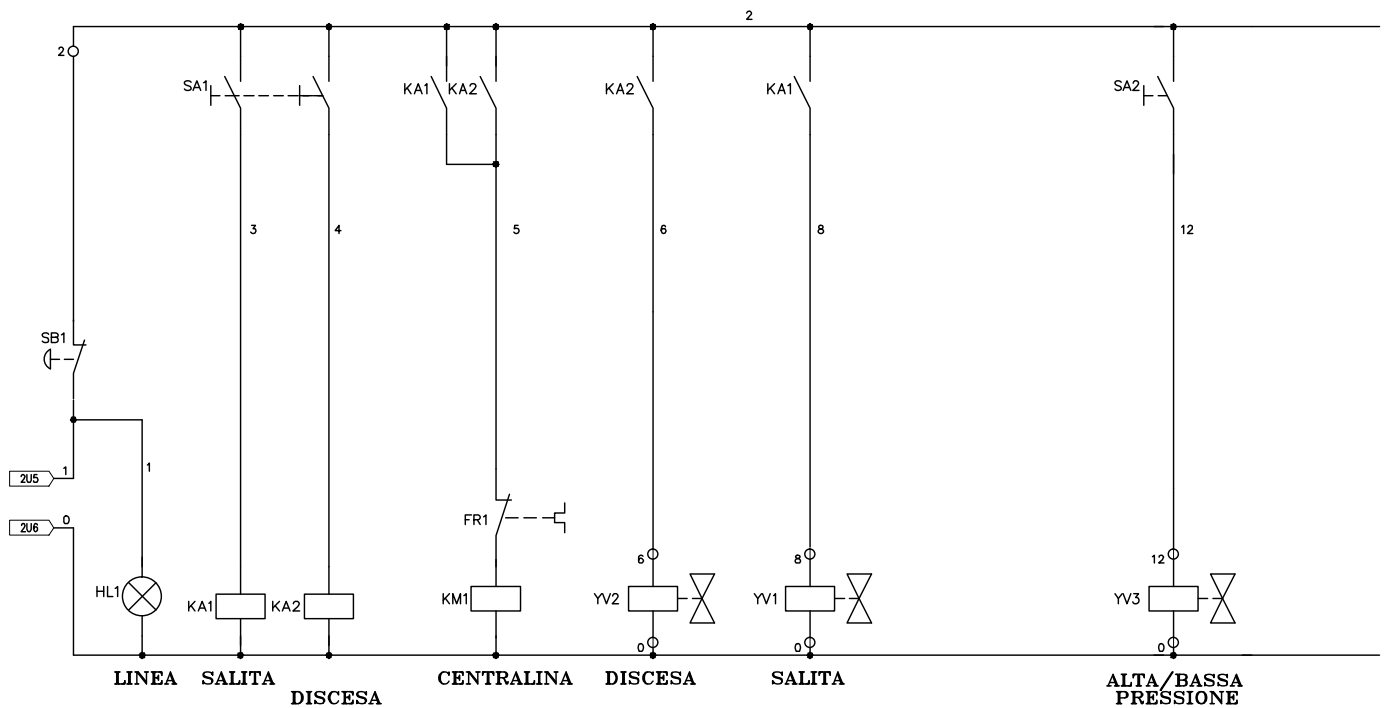

MADE IN ITALY

WIRING DIAGRAM

MPB SEMI

2P 230-400V 50-60Hz

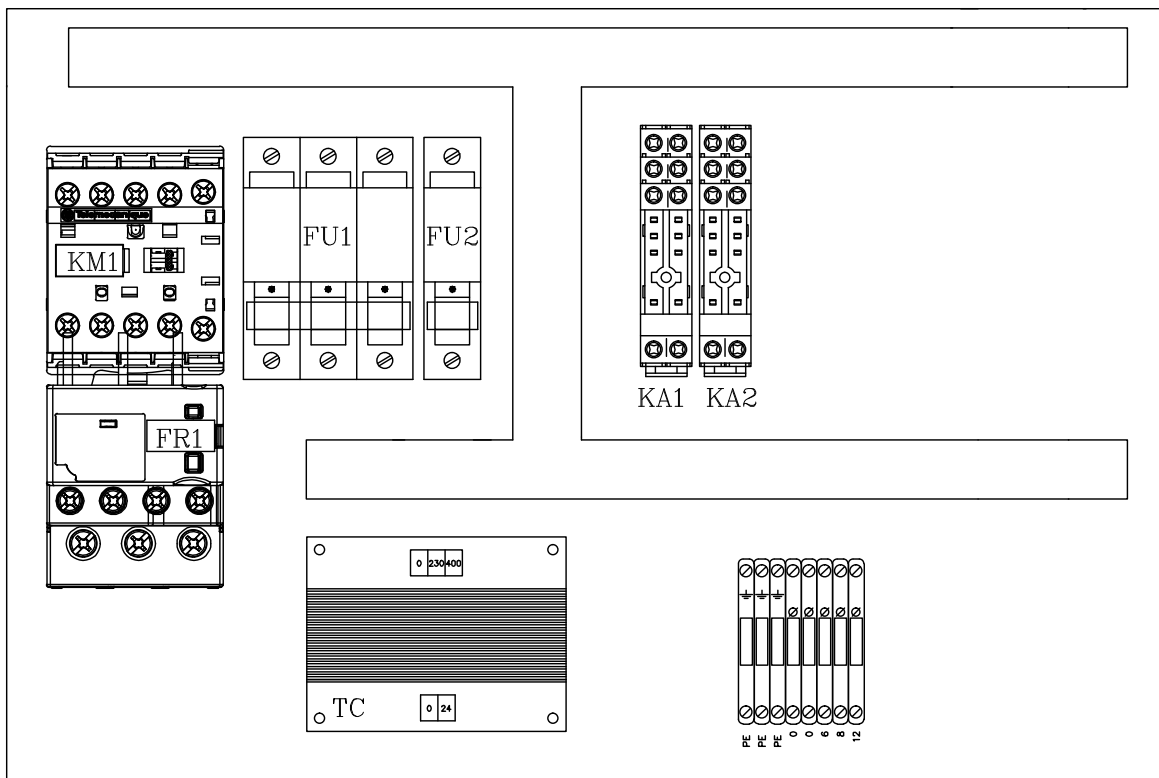

MADE IN ITALY

WIRING DIAGRAM

MPB SEMI

2P 230-400V 50-60Hz

IE100007 ELENCO MATERIALE QUADRO PER PRESSA S/AUTOMATICA SQ 400V 50-60Hz

SIGLA	DESCRIZIONE	COSTRUTTORE	MODELLO	QUANTITA'
	CASSETTA DERIVAZIONE 300X220X120	OLAN	OL20025	1
	PIASTRA PER IMPIANTI S/SCHEDA	ZETA 6	P300026	1
	STAFFA FISSAGGIO QUADRO ELETTRICO	ZETA 6	20100417	1
QS1	SEZIONATORE 16 A 3 POLI A PANNELLO	A.B.B.	OT16FT3	1
	MANIGLIA BLOCCO PORTA GIALLO/ROSSA	A.B.B.	OHYS2PJ	1
	SCATOLA ALIMENTAZIONE	ZETA 6	20120324	1
TC	TRASFORMATORE MONOFASE 100VA 0-230-400/0-24	TECNOCABLAGGI	TCN150052	1
KM1	TELERUTTORE 6A 24VAC MOTORE CENTRALINA	SCHNEIDER ELECTRIC	LC1K0610B7	1
FR1	RELE' TERMICO 1,8/2,6A MOTORE CENTRALINA	SCHNEIDER ELECTRIC	LR2K0308 (1,8/2,6A)	1
KA1	ZOCCOLO RELE' SALITA	FINDER	95.75	1
	RELE' 24VCA SALITA	FINDER	40.52.8.024	1
KA2	ZOCCOLO RELE' SALITA	FINDER	95.75	1
	RELE' 24VCA SALITA	FINDER	40.52.8.024	1
FU1	PORTAFUSIBILE TRIPOLARE	SOCOMECC	57010018	1
	FUSIBILE 10X38 16A GG	OMEGA	GL138316	3 + 3
FU2	PORTAFUSIBILE UNIPOLARE	SOCOMECC	57010015	1
	FUSIBILE 10X38 4A GG	OMEGA	GL138204	1 + 1
	MORSETTO TERRA 2,5mmq	WEIDMULLER	AKE2,5PA	3
	MORSETTO 2,5mmq	WEIDMULLER	AKZ2,5PA	5
	PIASTRINA TERMINALE	WEIDMULLER	AP AKZ2,5	1
	PANNELLO METALLICO PULSANTIERA S/AUTOMATICA	ZETA 6	20120298	1
	SERIGRAFIA PULSANTIERA PER PRESSA S/AUT.	SAPONARO	60850004	1
	CARTER RIPARO PULSANTIERA	LIRAS	65610001	1
SB1	PULSANTE DI EMERGENZA	SCHNEIDER ELECTRIC	ZB4BS844	1
	CORPO CONTATTI 1NC	SCHNEIDER ELECTRIC	ZB4BZ1025	1
HL1	SPIA PRESENZA RETE	SCHNEIDER ELECTRIC	ZB4BZ009 + ZBVB15	1
SA1	MANIPOLATORE 2 POSIZIONI	PIZZATO	E2 AC-DXBC2600	1
SA2	SELETTORE 2 POS. ALTA/BASSA PRESSIONE	SCHNEIDER ELECTRIC	ZB4BD2	1
	CORPO CONTATTI 1N0	SCHNEIDER ELECTRIC	ZB4BZ1015	1
YV1	ELETTROVALVOLA SALITA	-	KA132R13B9 (C/CIRCUITO)	1
YV2	ELETTROVALVOLA DISCESA	-	KA132R13B9 (C/CIRCUITO)	1
	ELETTROVALVOLA ALTA/BASSA PRESSIONE	-	KA132R13B9 (C/CIRCUITO)	1
	RACCORDO PER GUAINA DIAM. 16 PG13,5	DIELECTRIX	DX54416	2
	PRESSACAVO ANTISTRAPPO PG11 + DADO	CEMBRE	1900.11 + 1711	3 + 3
	PRESSACAVO ANTISTRAPPO PG13,5 + DADO	CEMBRE	1900.13 + 1712	1 + 1

FOGLIO 05

Materials list

WIRING DIAGRAM

MPB SEMI

230V 60Hz 3Ph UL-CSA

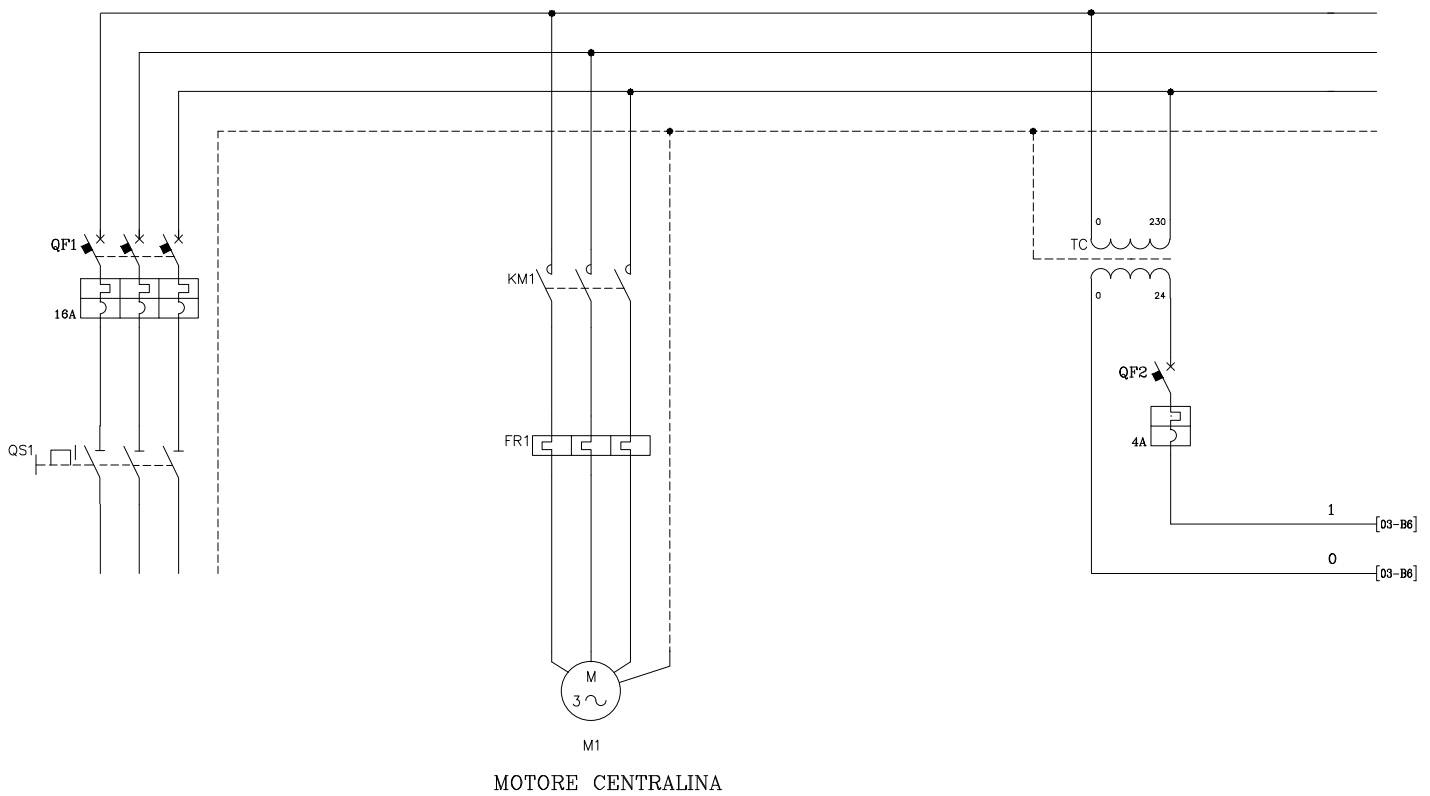

WIRING DIAGRAM

MPB SEMI

230V 60Hz 3Ph UL-CSA

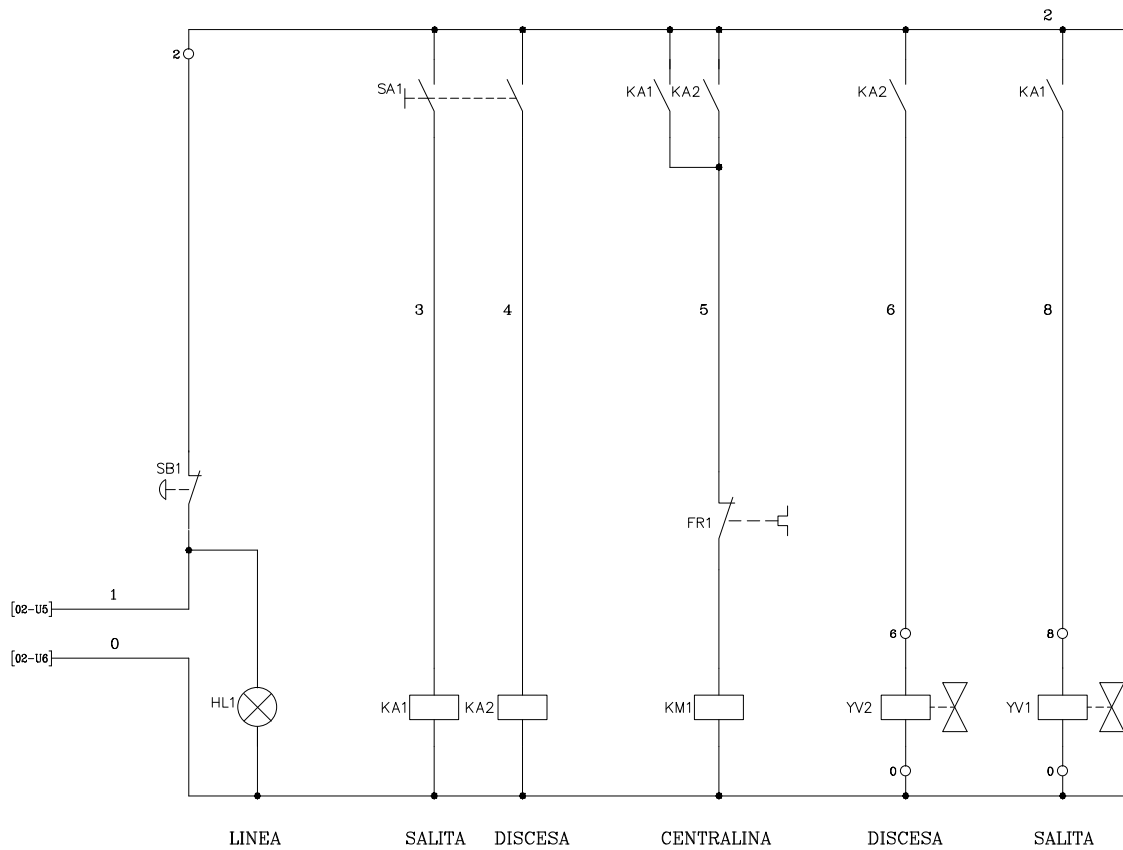

MADE IN ITALY

WIRING DIAGRAM

MPB SEMI

230V 60Hz 3Ph UL-CSA

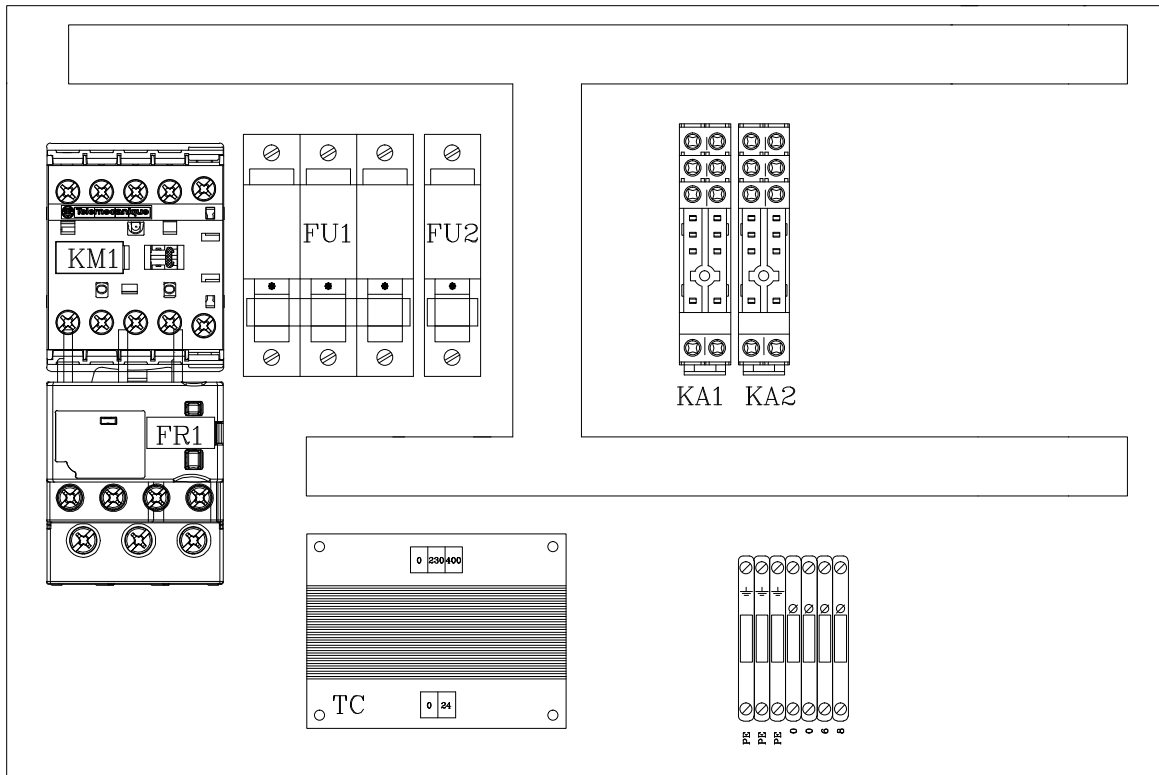

MADE IN ITALY

WIRING DIAGRAM

MPB SEMI

230V 60Hz 3Ph UL-CSA

IE400006 ELENCO MATERIALE QUADRO PER PRESSA S/AUTOMATICA SQ 230V 60Hz UL-CSA

SIGLA	DESCRIZIONE	COSTRUTTORE	MODELLO	QUANTITA'
	CASSETTA METALLICA 300X250X150	QUADRITALIA	STB302515SF	1
	STAFFA FISSAGGIO QUADRO ELETTRICO	ZETA 6	20100417	1
TC	TRASF. MONOFASE UL-CSA 100VA 0-115-208-230 / 0-24	TECNOCABLAGGI	TCN26000160.078	1
QS1	SEZIONATORE 16 A 3 POLI A PANNELLO	A.B.B.	OT16FT3	1
	MANIGLIA BLOCCO PORTA GIALLO/ROSSA	A.B.B.	OHYS2PJ	1
	SCATOLA ALIMENTAZIONE	ZETA 6	20120324	1
QF1	INTERRUTTORE AUTOMATICO TRIPOLARE 16A	A.B.B.	S203 C16	1
QF2	INTERRUTTORE AUTOMATICO UNIPOLARE 4A	A.B.B.	S201 C4	1
KM1	TELERUTTORE 6A 24VAC MOTORE CENTRALINA	SCHNEIDER ELECTRIC	LC1K0610B7	1
FR1	RELE' TERMICO MOTORE CENTRALINA	SCHNEIDER ELECTRIC	LR2K0312 (3,7-5,5A)	1
KA1	ZOCCOLO RELE' SALITA	FINDER	95.75	1
	RELE' 24VCA SALITA	FINDER	40.52.8.024	1
KA2	ZOCCOLO RELE' SALITA	FINDER	95.75	1
	RELE' 24VCA SALITA	FINDER	40.52.8.024	1
	MORSETTO TERRA 2,5mmq	WEIDMULLER	AKE2,5PA	3
	MORSETTO 2,5mmq	WEIDMULLER	AKZ2,5PA	4
	PIASTRINA TERMINALE	WEIDMULLER	AP AKZ2,5	1
	PANNELLO METALLICO PULSANTIERA S/AUTOMATICA	ZETA 6	20120298	1
	SERIGRAFIA PULSANTIERA PER PRESSA S/AUT.	SAPONARO	60850005	1
	CARTER RIPARO PULSANTIERA	LIRAS	65610001	1
SB1	PULSANTE DI EMERGENZA	SCHNEIDER ELECTRIC	ZB4BS844	1
	CORPO CONTATTI 1NC	SCHNEIDER ELECTRIC	ZB4BZ1025	1
HL1	SPIA PRESENZA RETE	SCHNEIDER ELECTRIC	XB4BVB1	1
SA1	MANIPOLATORE 2 POS. + BLOCCHETTO CONT. 2 NO	PIZZATO	E2AC-DXBC2600	1
YV1	ELETTROVALVOLA SALITA	PROTEKNA	7000-18301-6360150	1
YV2	ELETTROVALVOLA DISCESA	PROTEKNA	7000-18301-6360150	1
	RACCORDO PER GUINA DIAM. 16 PG13,5	DIELECTRIX	DX54416	2
	PRESSACAPO ANTISTRAPPO PG13,5 + DADO	CEMBRE	1900.13,5 + 1712	3 + 3
	PRESSACAPO ANTISTRAPPO PG11 + DADO	CEMBRE	1900.11 + 1711	1 + 1

Materials list